

# Operational Manual

## CM-IR15-850 Illuminator

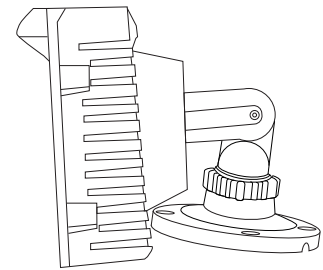

The lightning flash with arrowhead symbol, with an equilateral triangle, is intended to alert the user to the presence of "uninsulated" dangerous voltage within the product's enclosure that may be of sufficient magnitude to constitute a risk of electric shock to persons.

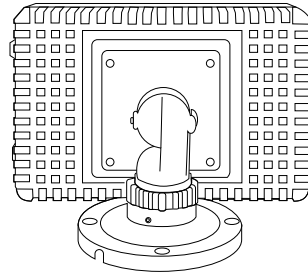
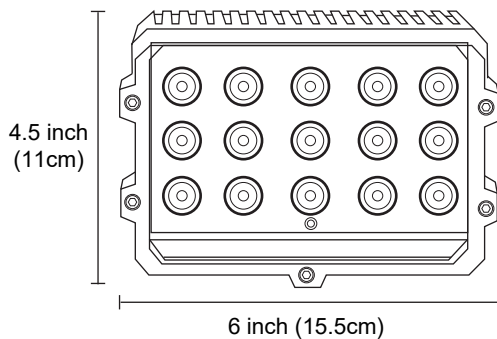

The crossed-out wheeled bin mark symbolizes that within the European Union the product must be collected separately at the product end-of-life. This applies to your product and any peripherals marked with this symbol. Do not dispose of these products as unsorted municipal waste.



**RoHS** Announcement (Option)  
All lead-free products offered by the company comply with the requirements of the European law on the Restriction of Hazardous Substances (RoHS) directive, which means our manufacture processes and products are strictly "lead-free" and without the hazardous substances cited in the directive.



CE Mark  
This apparatus is manufactured to comply with the radio interference.



This exclamation point within an equilateral triangle is intended to alert the user to the presence of important operating and maintenance (servicing) instructions in the literature accompanying the appliance.

### FCC NOTICE

This equipment has been tested and found to comply with the limits for a class of a digital device, pursuant to part 15 of the FCC Rules. These limits are designed to provide reasonable protection against harmful interference when the equipment is operated in a commercial environment.

This equipment generates radio frequency, and if not installed and used in accordance with the instruction manual, may cause harmful interference.

### Feature:

CM infrared lighting serial products can be used for indoor and outdoor low illumination surveillance security system. Under outdoor circumstance, these infrared illuminators can be worked and controlled by PTZ (Pan Tilt Zoom) controller, while under indoor circumstance, infrared illuminators can be fasten to fixture or controlled by PTZ either to monitor large lobby area. To make sure infrared illuminators fully functional, special CCTV cameras featured with low illumination, infrared ray sensitivity are required. If CCTV cameras are not sensitive to 850nm infrared, these infrared lights will not show well function.

### Specification:

Item No.	CM-IR15-850
Input voltage	DC 12V
Wavelength	850nm
Activate Lux	10 Lux
Product Features:	IR LED
	15 PCS 20mil of High Power IR LED
	50-100M IR Night vision
	30°/45°/60°/80° light angle is optional
	Suitable for long distance IR Illumination
Power Consumption	18 W
Water Resistance	IP 65
Weight (g)	1100g
Storage Temperature	-30~+60°C RH95% Max
Operating Temperature	-10~+50°C RH95% Max

### Installation:

According to physical construction and view of infrared lights, infrared lights should be installed on wall, bracket (or PTZ controller). In order to make infrared lights effective, best time for installation would be night time. The goal is to adjust infrared lights to ensure camera image very clear.

### Connection:

The illuminator has a wired power input socket. The center of the socket is positive pole. The socket is connected to 12V DC power supplier.

### Notes:

To ensure longer lifetime and more efficient, infrared light must be used with stable 12V DC power source. The voltage range should be within 12V±5%, if voltage is too high the infrared lights will be damaged, if voltage is too low, the infrared lights will not work properly.